

029g

IN SWINGING DOOR electric

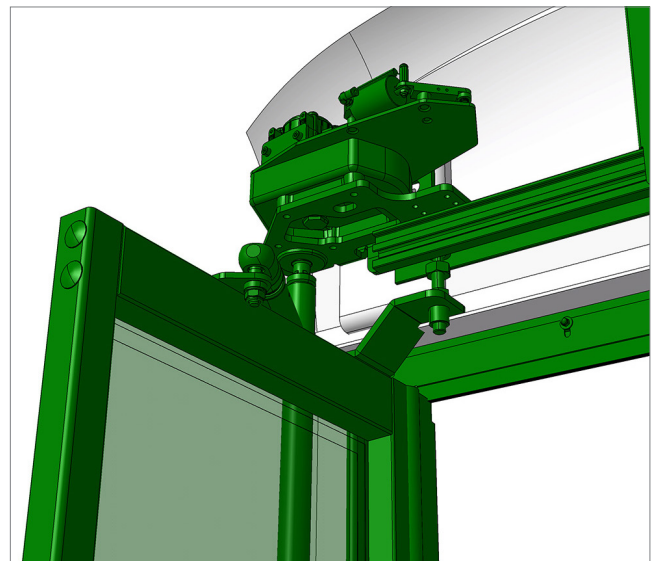
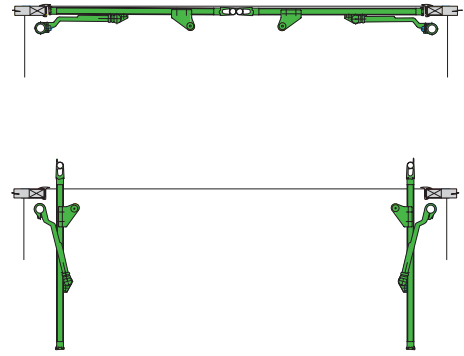

DESCRIPTION

- Inward-opening electric door.
- Separate operation of door leaves. (optional)
- Pneumatic emergency system with buttons with transparent cover, and Led lighting. (optional)
- Module DM1 Masats (emergency)
- Ready for single or double leaf glass doors.
- Emergency override at vehicle speed > 3 km/h.
- Sensitive edge, electric. (optional)
- Doors in RAL9011 black.
- Sensitivity setting by Masats' multiplexed CAN BUS ECU electronic control box adaptable to the vehicle.
- Locks can be built into the bottom profile. (optional)

ADVANTAGES

- Easy assembly and reduced installation time.
- Fixing anchorages common with other sliding door systems, making it possible to interchange it with other equipment.
- The mechanical components, such as leaves, bars and supports, are common between the electrical and pneumatic versions.
- Masats' modular handles.

TECHNICAL DATA

- Working temperature: -30 °C to +70 °C
- Nominal voltage: 12/24 V ± 20%
- Complies with regulation UN R107.
- For Class I and II vehicles.