

RE1

ELECTRIC RAMP

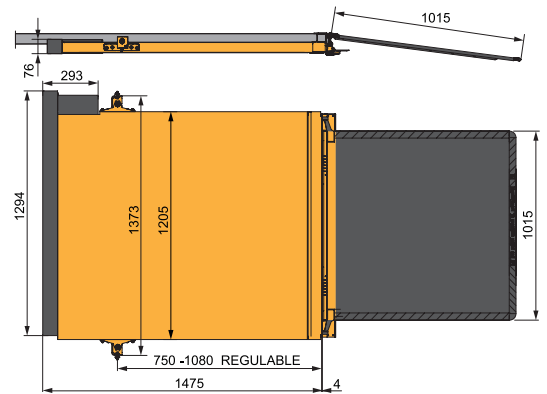

DESCRIPTION

- Electric ramp 12/24v.
- Designed to be mounted under the vehicle's floor.
- Reduced thickness: 60 mm
- Weight: 82,5 Kg
- Load: 350 Kg
- Vehicles destined for Class I, A.
- Complies UN regulations R107

BENEFITS

- Located under the floor.
- Once the platform is extended, it remains at the vehicle's floorlevel.
- It's provided with a front sensitive rubber protection, in order to detect any obstacle placed at the front. In this case, the ramp moves automatically in.
- The platform is sensitive to weight, both in static and in dynamic phase. When detecting a weight heavier than 15kg, it remains immobilized in static phase, and it stops in dynamic phase.
- Lifting system for thickness 60-70 80.

